

ProAudio8

BY PULSEEIGHT

DSP AUDIO MATRIX

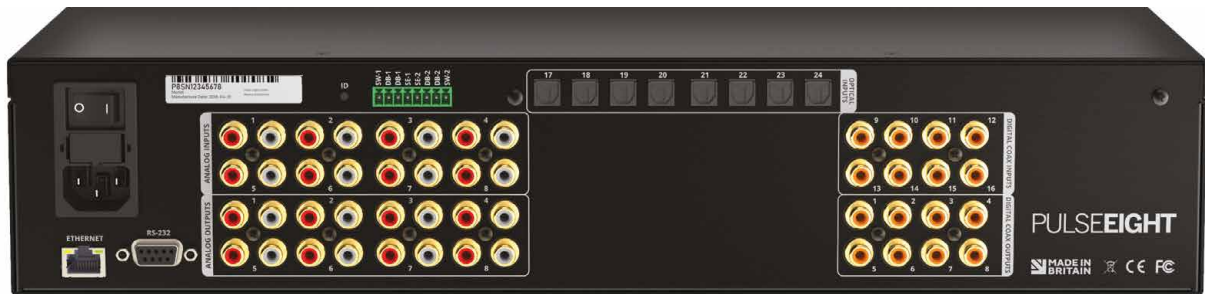

24 AUDIO INPUTS



8 AUDIO OUTPUT ZONES



LIP SYNC DELAY



THIRD PARTY CONTROL



C4 SDDP



FULL DSP

TECHNICAL SPECIFICATIONS

SKU: P8-PROAUDIO8

Audio Inputs: 24

Stereo L/R Audio Inputs: 8

Optical Audio Inputs: 8

Digital Coax Audio Inputs: 8

Audio Outputs: 8

Stereo L/R Audio Outputs: 8

Optical Audio Outputs: 8

12V Triggers: 0

Serial Control: Yes - RS232

TCP/IP Control: Yes

Third Party Control: Yes - Drivers available

Lip Sync Delay: Up to 170ms per zone

Volume Adjustments: 20db to +20db 0.5db steps

Equalizer: 5 band EQ per zone

Subwoofer Control: Yes

Treble: -20db to +20db 0.5db steps

Equalizer: 5 band EQ per zone

Input Gain Control: 24db to +24db

Output Gain Control: -24db to +24db

Doorbell/Paging Inputs: 2

Supported Formats: PCM, Dolby Digital 5.1, DTS

Coax Input Levels: 200mV-7.0V (PC card compatible)

Coax Output Level: 500mV nominal into 75 ohms

Freq. Response: 5Hz-20KHz @ +/-0.1dB S.N

Ratio: > 85dB, 5Hz-20KHz

Input Impedance: 10K ohms

Third Party Drivers Available: Control4, Crestron, Elan, RTI and Savant

Power Supply: IEC C14 input - 110-240V, 1.0A, 50/60 Hz

Material: Brushed Aluminium (Anodised)

Product Dimensions: 44 x 8 x 22 cm - 2U

Product Weight: 2 kg

Operating Temp Range: -10 to +70°C (14 to +158°F)

Storage Temp Range: -20°C to 60°C (-4°F to 140°F)

Humidity Range: 5 to 90% RH (no condensation)

Safety & Emissions: UKCA, CE, FCC, RoHS

Manufactured In: Great Britain by Pulse-Eight



CONCEPT WIRING DIAGRAM: ProAudio8, neo:8a and ProAmp8

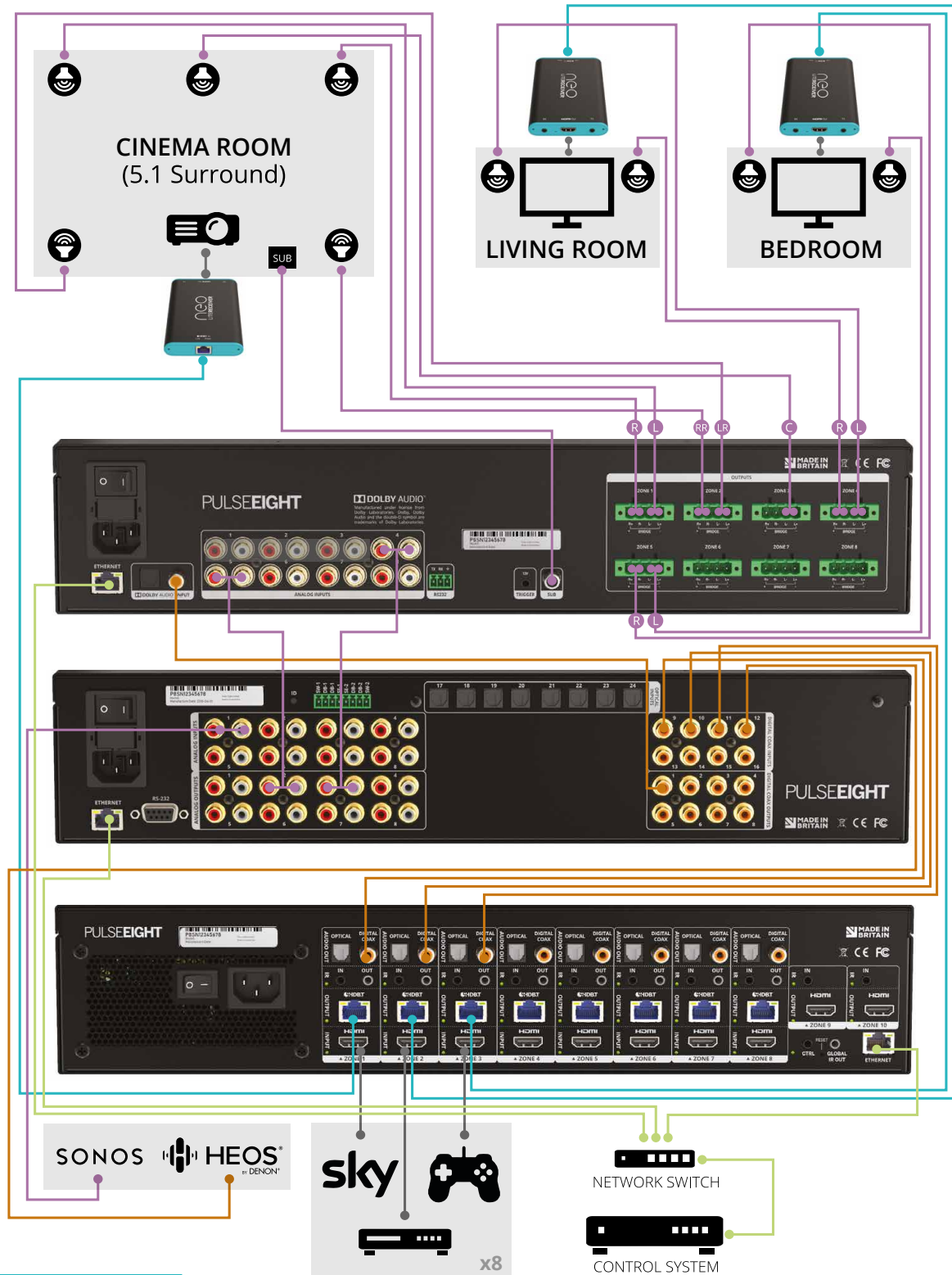

LEGEND

- Infrared
- HDBaseT
- Ethernet
- HDMI
- Analogue Audio
- Digital Audio



COMPATIBLE CONTROL SYSTEMS

- Control4 CRESTRON
 ELAN RTI SAVANT